



This manual is for reference and historical purposes, all rights reserved.

**This page is copyright© by M. Butkus, NJ.**

This page may not be sold or distributed without the expressed permission of the producer

I have no connection with any camera company

On-line camera manual library

This is the full text and images from the manual. This may take 3 full minutes for the PDF file to download.

**If you find this manual useful, how about a donation of \$3 to: M. Butkus, 29 Lake Ave., High Bridge, NJ 08829-1701 and send your e-mail address so I can thank you. Most other places would charge you \$7.50 for a electronic copy or \$18.00 for a hard to read Xerox copy.**

**This will allow me to continue to buy new manuals and pay their shipping costs.**

**It'll make you feel better, won't it?**

**If you use Pay Pal or wish to use your credit card,  
click on the secure site on my main page.**



Olympus  
**Pen**

First 1/2-Frame Single Lens Reflex Camera in the World!



**INSTRUCTIONS**

The Olympus Pen F is the newest of the popular "Olympus Pen" series. This single-lens reflex camera features lightness of weight, maximum flexibility and ease of operation.

There are several new features, which make it important for you to read this instruction booklet carefully before using your Olympus Pen F.

Please lift this over-leaf.

The index numbers here correspond with numbered explanations on following pages.

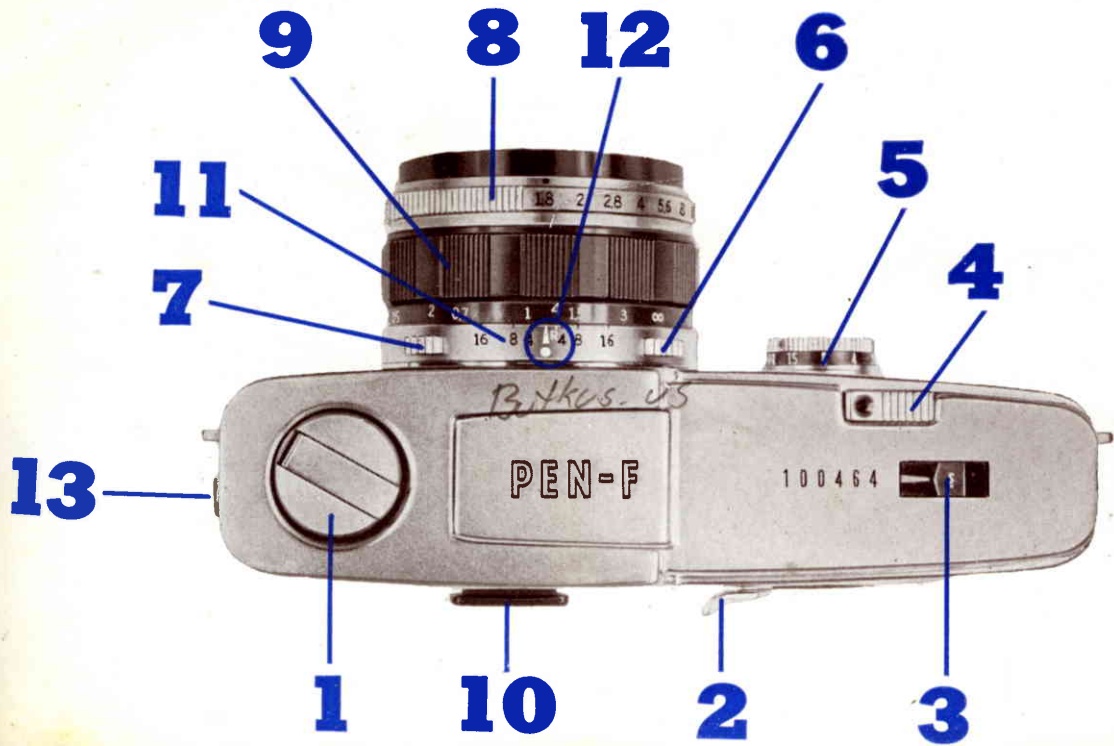

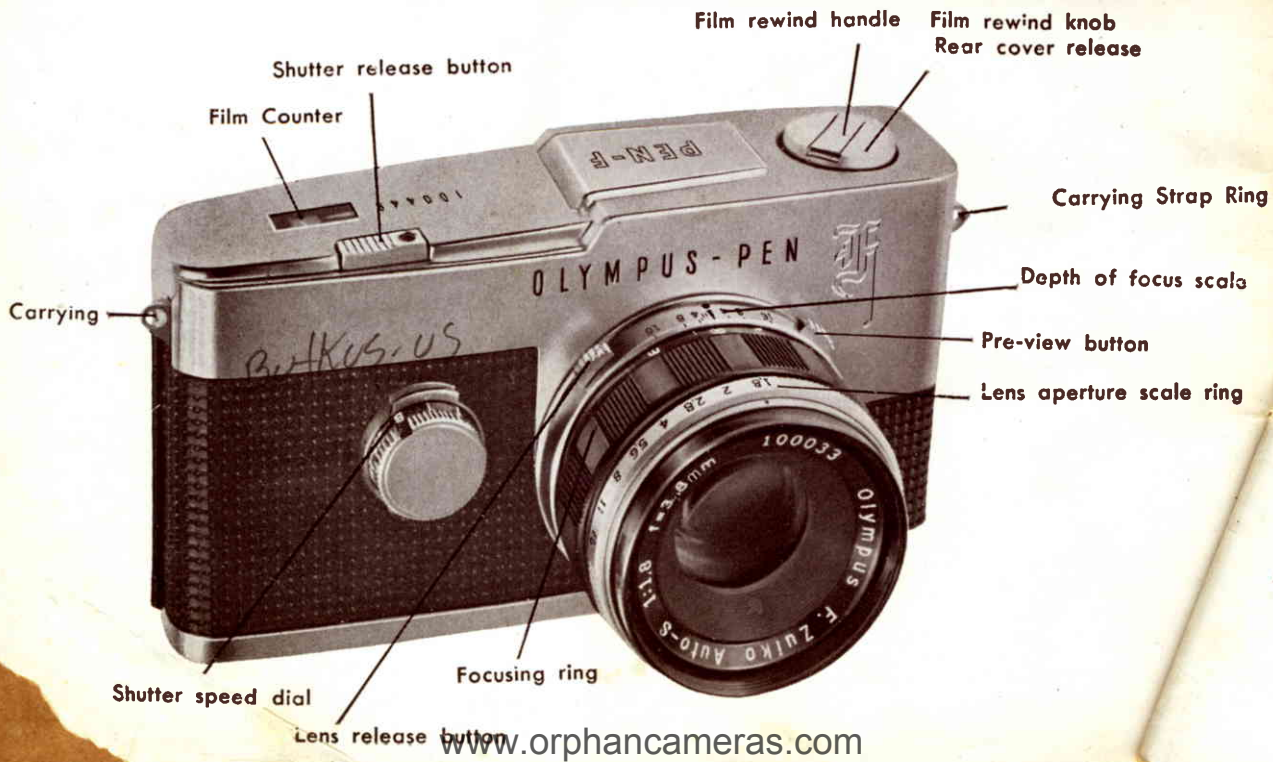

Film advance lever

Range finder

Sprocket

Film rewind shaft

Take-up spool

Film housing

Tripod stabilizer

Shutter curtain

Film guide rail

*Butkus 205*

Tripod socket

Rewind release button

Film pressure plate



OLYMPUS - PEN



OLYMPUS F. 2/11.8  
1:3.8cm



## SPECIFICATIONS

- Film size** : 24×18 mm ("Pen" size) (15/16×11/16 in.)
- Lens** : Standard lens: F Zuiko Auto S, F 1.8 f=38 mm (1 1/2 in.)
- Lens mount** : Bayonet type (Pen mount)
- Shutter** : Olympus rotary metal focal-plane shutter with single-pivot, non-revolving shutter dial. Synchronized for electronic flash use. B. 1—1/500 sec., equally calibrated. X setting.
- Finder** : Through-the-lens type. Image magnification 0.8 X. Porroprism system with Fresnel lens.
- Focus adjustment** : Specially computed focusing lens with 5 X magnifier
- Mirror** : Horizontally revolving, quick return.
- Film advancing** : Double action with 90° self-cocking lever. Double exposure impossible. Self resetting type film counter.
- Rewinding** : Crank system with rewind release button.
- Rear cover** : Hinge system with release built into rewind knob.
- Size** : Width: 5 in. (127 mm)  
Height: 2 3/4 in. (69.5 mm)  
Depth: 2 1/2 in. (62.5 mm) with standard lens  
1 1/4 in. (32.5 mm) body only
- Bulkus-05*
- Weight** : 1 lb. 3 oz. (560 gr.) with standard lens



# 1

## OPENING THE BACK COVER

Open the over-leaf of the inside front cover of this booklet. Numbered parts correspond with the sections on the following pages.

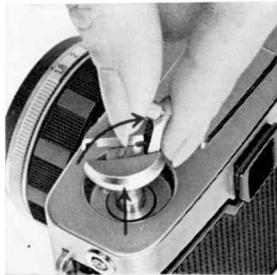

Lift the film rewind handle and pull the knob upward until it stops once. Pull the knob again, this time with more pressure, and the back will open automatically.

To close, press the back cover until it snaps tight. The rewind knob may be left as it is.

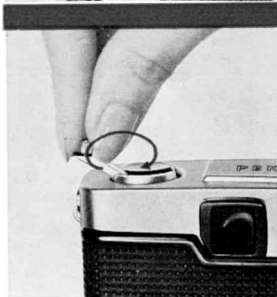

To rewind film, turn the handle in the direction indicated by the arrow. (clockwise)

# 2

## FILM ADVANCING

Film advancing is done by a double action system. Place your thumb on the lever and move it to the right until it stops. Allow the lever to return to its original position, and then advance it again. If the film is not fully advanced the shutter cannot be released. Also, if the shutter is not released, the film cannot be advanced.

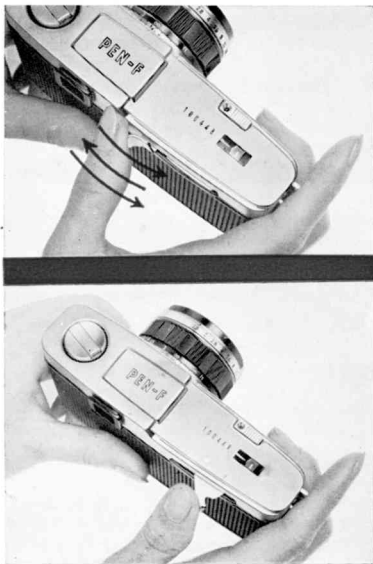

### Film Advance Lever

This double action lever does the following things :

1. Advances single frames of film.
2. Advances the film counter.
3. Presets the shutter.
4. Swings the mirror into position.
5. Presets the automatic aperture system.

### 3

## FILM COUNTER

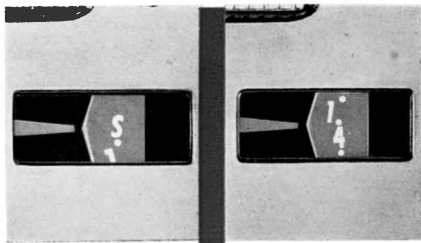

The film counter starts from "S" and continues through 72, counting by 4 s. i. e. S, 1, 4, 8, 12, 16, etc.

Single frames are advanced by the film advance lever but, due to size, this is not indicated on the film counter.

The orange colored arrow shows the number of frames exposed.

When the rear cover is opened, the film counter returns to "S" automatically.

### 4

## SHUTTER RELEASE BUTTON

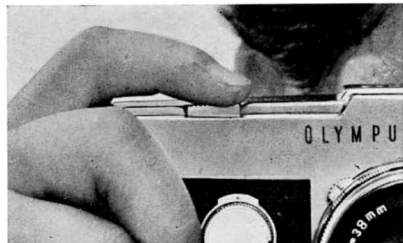

When holding the camera the index finger rests naturally on the shutter release button. The Pen F is rectangular in shape so that the shutter release button may be activated with only slight pressure from the flat part of this finger.

The threaded hole inside the button is for attaching a cable release or



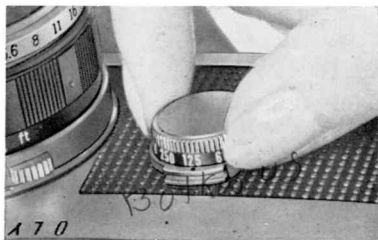

To set shutter speed, turn the dial until the corresponding number is aligned with the red dot. B (bulb)—In this setting the shutter leaves are opened when the shutter release button is pressed, and will remain open until it is released. B is used when exposures of longer than one second are desired. The numbers 1 through 500 stand for fractions of a second. i. e. 1 = 1 sec., 2 =  $\frac{1}{2}$  sec., etc. through 500 =  $\frac{1}{500}$  sec.

For the correct speed, ensure that the number is perfectly matched with the red dot. The dial may be turned in either direction. Speed may be set either before or after advancing the film.

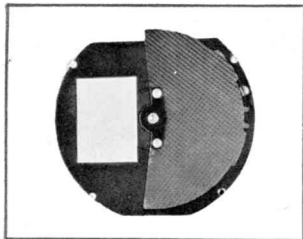

#### Rotary Metal Focal Plane Shutter

The newly designed shutter on the Pen F is completely different from other types of focal plane shutters. It contains a semi-circular titanium screen (50 mm diameter) which rotates in a clockwise direction at a distance of 1.6 mm from the film.

This shutter works so rapidly that regardless of shutter speed it never fails to open completely, making it possible for an electronic flash to be synchronized with it at speeds of from 1 to  $\frac{1}{500}$  of a second. (With other focal plane shutters this is impossible when speeds exceed  $\frac{1}{60}$  th of a second.)

## 6

## LENS RELEASE BUTTON

Bayonet-mounted lenses for the Pen F are easily removed and replaced. On the base of the lens there are two buttons, one of which is marked with a red L (lock). This is the lens release button.

First, hold the camera in the left hand and grasp the base of the lens with the right hand. Then press the lens release button with the thumb of the right hand and turn the lens in a clockwise direction until it stops. The lens is removed by pulling it away from the camera body.

To remount the lens, insert it carefully into the body, aligning the red mark (⊙) on the lens with the red dot on the body. Turn the lens in a counter-clockwise direction until the lens release button (L) returns with a click.

It is not necessary to move the lens release button when mounting the lens.

It locks into place automatically.



## REMOVAL



## REPLACEMENT





## 7

### PRE-VIEW BUTTON (to verify aperture selection)

The unmarked button on the base of the lens is called the "pre-view button". Even after the aperture on the Pen F is set, it will not close down to this opening unless the shutter release button is pressed. At all other times the aperture is wide open. This completely automatic aperture system allows focusing and framing at full brightness.



The pre-view button on the Pen F closes the pre-set opening, making it possible to see the subject through the viewfinder with the same brightness as that of the aperture setting. (See Section 11, Depth of Focus Scale.) This ensures perfect focusing of both subject and background.

## 8

### LENS APERTURE SCALE RING

The ring which is around the top of the lens body is the lens aperture scale ring. It is numbered 1.8, 2, 2.8, 4, 5.6, 8, 11 and 16. The larger numbers indicate smaller aperture openings, and the converse. Turn this ring and align its numbers with the black dot to change the aperture opening. Unlike the shutter speed, the aperture may be set between numbers.

While viewing through the finder, turn the lens distance scale ring in either direction until the subject is most clearly visible. The shutter release button may then be pressed. Clear, sharp photography. The lens distance scale ring has scales in two different colors; white (meters) and yellow (feet). These indicate distance between the camera and the subject in focus.



The main feature of the Pen F finder is that the subject viewed through the finder and the photograph are exactly the same. i. e. The "photograph" is seen through the finder. Even when the distance to the subject is short, or a telephoto lens is used, the subject is perfectly framed in the viewfinder. Not only is it possible to capture the feeling of distance and background, but the full effect of color is assured.

Directly behind the lens is a rectangular-shaped mirror which swings horizontally on a pivot. The left side of the mirror is a focal plane. Light enters through the lens, is reflected by the mirror and forms an image on a focal plane through the Fresnel Lens. This image passes through both prisms and a 5 X magnifier.

Magnification of the finder is 0.8 times with the standard lens, which has a focal length of  $f=38$  millimeters.

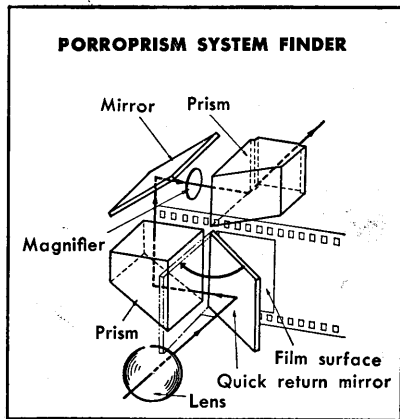



When the camera is focused at a certain distance, only the subject is exactly in focus. Other objects appear in the viewfinder out of focus. The range in front of and behind the subject in which objects are in reasonably sharp focus is called "the depth of focus".

Depth of focus changes, depending upon the lens focusing distance and aperture opening. When this range is broad, the depth of focus is said to be "deep". To make the depth of focus deeper, either lengthen the lens focusing distance or reduce the size of the aperture opening. A third method is to focus upon an object which is further from the camera than the subject.

#### Using Depth of Focus

Depth of focus can be adjusted by making the aperture opening larger or smaller. Both near and far objects can be brought into focus by reducing the aperture opening. For portrait photography the subject can be emphasized by enlarging the aperture opening to take the background out of focus.

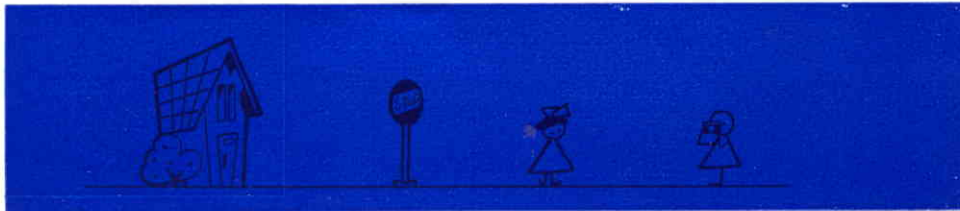

## Reading the Depth of Focus Scale



The depth of focus is indicated by a set numbers ; 4, 8 and 16 ; which correspond to aperture openings and are written on each side of the red mark (∅). Reading the depth of focus is explained by the following example : The distance between the camera and the subject is 1.5 feet and the aperture setting is 8. Depth of focus is indicated between 8 to the left of the mark (1.1 ft.) and 8 to the right of the mark (1.7 ft.).

The focused range can also be determined by pressing the pre-view button while viewing through the finder, as explained in Section 7.

This is the infra-red indicator. To use infra-red sensitive film, set the focus first, and move the depth of focus ring to the "R" mark. Infra-red photography requires a red filter.

Now you are ready to use the Olympus Pen F. But, before taking pictures, try every part again.

### Seven steps for everyday photography

- ① Load the film.
- ② Set the shutter speed.
- ③ Determine the aperture opening.
- ④ Move the film advance lever twice.

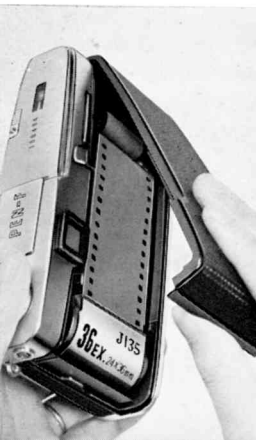

⑤ Hold the camera and compose the picture.



⑥ Set the focus.



⑦ Press the shutter release button.



When composing the picture it is helpful to test the effect of the aperture opening by pressing the preview button.

**F**

## FILM SIZE OF THE PEN F



(Pen Size)

The Pen F uses standard size 35 mm (135) film, which is available anywhere.

The pictures are "Pen" size ( $15/16 \times 11/16$  inches), half of the 35 millimeter size ( $13/8 \times 17/8$  inches).

This size is very economical, especially for colored slides, because 72 pictures can be taken on a roll of 36 and 40 on a roll of 20.

(35 mm Size)



## LOADING THE FILM

Use a roll of  
35 mm (135) film  
with either 20 or  
36 exposures.



- ① Open the rear cover. Lift the film rewind knob until it stops. Pull it again, this time with more pressure, and the rear cover will open. (See Section 1).

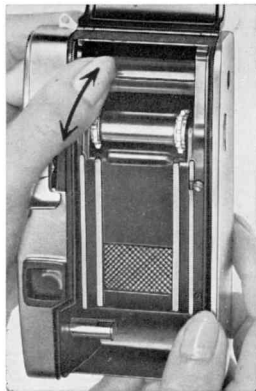

- ② Hold the camera as shown above and turn the film rewind shaft until the slot on the shaft is on top. (The rewind shaft will turn freely.)

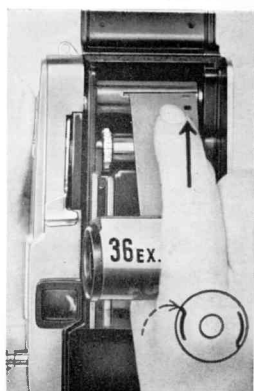

- ③ Holding the film cassette, insert the end of the film into the slot and move it to the right edge as shown.

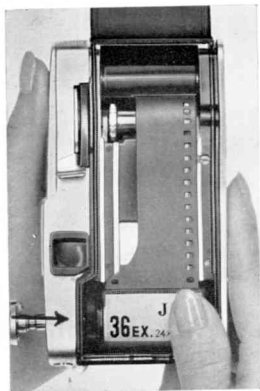

- ④ Put the film cassette into the film housing and push the rewind knob in. If the knob cannot be pushed in completely, twist it back and forth slightly, while maintaining pressure.

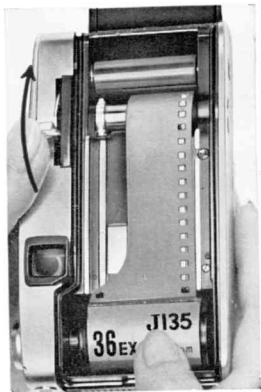

- ⑤ With the thumb of the right hand, wind the film forward lever, making sure that the perforation on the right-hand side of the film meshes perfectly with the sprocket.

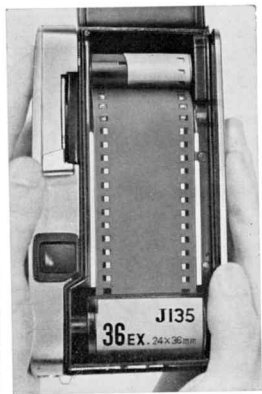

- ⑥ Advance the film until the perforations on both sides mesh with their corresponding sprockets. (The shutter must be released at every second movement of the lever.)

Be sure that the film is placed inside the guide rails (shiny rails at the extreme sides).

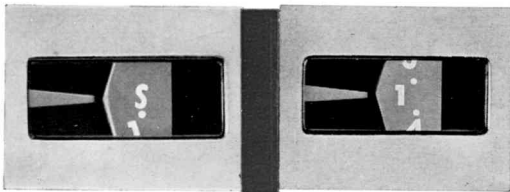
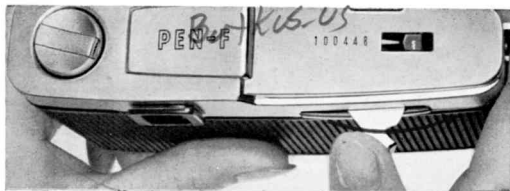

⑦ Close the back cover

To take up slack in the film, lift the film rewind handle and turn it in a counter-clockwise direction until it becomes tight.

⑧ Wind the film advance lever (pressing the shutter release button every second time) until the film counter moves to 1. If the film rewind knob turns during this operation, the film is advancing correctly.

(The camera is now ready to take pictures.)

**(NOTE)**

- ① Film loading should never be done in direct sunlight. Darker places are preferable.
- ② If the film is loaded improperly it may be impossible to take pictures. Be careful when



## FILM REWINDING

When a roll of film is completely exposed, cover the lens with the cap and rewind the film. The film is completely exposed when the film counter indicates either 40 or 72, depending upon the length of film used.

Press the rewind release button on the bottom of the camera body.

Lift the film rewind handle and turn it in a clockwise direction. This handle is tight while the film is being rewound, but when the end of the film leaves the take-up reel the handle will become loose.

Pull out the film rewind knob and remove the film, keeping it away from direct sunlight.

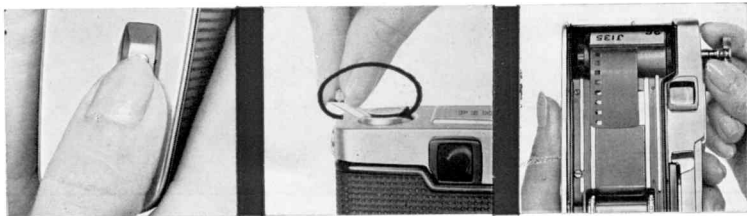

When the film is completely exposed the film advance lever becomes tight during its action and film cannot be advanced. Film is then rewound in the manner described above.

### (NOTE)

The film rewind knob should not be pulled out before the film is completely rewound. If the knob is pulled out by mistake, the back cover may open, exposing the film.

## **THINGS TO NOTE BEFORE PRESSING THE SHUTTER RELEASE**

- ① **Hold the camera firmly. (See the next page.)**
- ② **Press the shutter release button lightly.**
- ③ **Due to the smallness of the film size it is suggested that the camera be as close to the subject as possible in order to fill the frame completely.**
- ④ **When using slow shutter speeds (1/30—1 sec. and B) the camera should be placed on a tripod or other fixed object.**
- ⑤ **Good enlargements depend entirely upon good film development. The exposed film should be developed carefully.**

## **HOLD THE CAMERA NATURALLY AND FIRMLY**

Due to the small size of film used in the Pen F the camera should not be moved when pictures are taken. Movement will show up in enlargements. The camera may be held either horizontally or vertically, depending upon optimum composure of the picture.

When the camera is held horizontally the elbows should be steadied against the body.

When the camera is held vertically, the left hand is used to steady it and the right elbow is braced against the body.

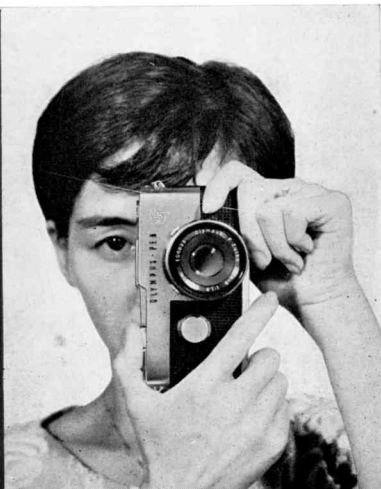
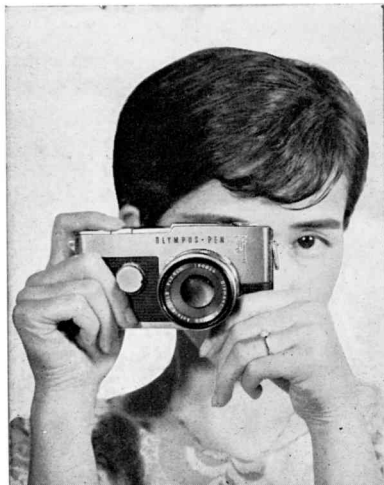

When using a tripod it is advisable to employ a cable release.



The shutter release button should be pressed with the flat part of the finger.

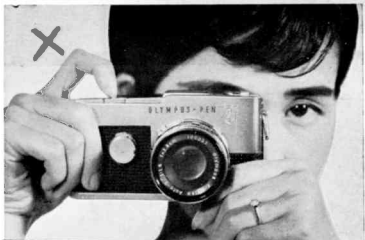

Use either flash bulbs or an electronic flash under conditions of poor light, or darkness.

Even in daylight photography, artificial light can be used to eliminate shadows caused by sunlight coming from behind the subject, or when the background is expansive.

The Pen F, different from ordinary focal plane shutter cameras, can synchronize an electronic flash at any shutter speed from 1 to 1/500 th of a second. This special feature makes it possible to use an electronic flash under daylight conditions.

### ATTACHING THE FLASH UNIT

The black colored eyepiece of the viewfinder is slightly raised from the camera body, leaving space to slide in the bracket which holds the flash unit. This bracket is an optional accessory.

The plug of the flash unit goes into the synchronized socket on the side of the camera body. This is the X socket.

### TYPES OF ARTIFICIAL LIGHT

Following are the three types of artificial light:

- (a) Electronic flash
  - (b) M Bulb
  - (c) F Bulb
- } Flash Bulbs

The amount of light emitted by each different bulb is indicated by guide numbers which are printed on their boxes. The aperture opening is determined by dividing the guide number by the distance to the subject. This is explained in more detail by the following example: ASA of the film is 100, shutter speed 1/60 sec., distance 5 meters and the bulb guide number is 40. Dividing the guide number of 40 by the distance of 5 gives the resultant aperture opening, 8.

## USING A SELF TIMER

Shutter Speed	B	1	2	4	8	15	30	60	125	250	500
Flash											
Electronic flash											
M Bulb											
F Bulb											

The above dark areas indicate the effective shutter speeds for electronic flash and for M and F bulbs.



Standard timers, of the type shown above, are attached to the shutter release button of the Pen F. Place the camera on a tripod, set the speed and aperture, and wind the self timer. The shutter will be released approximately eight seconds after the timer is activated.

**(NOTE)** Attaching and setting of the self timer should be done before advancing the film.

## CAUTION

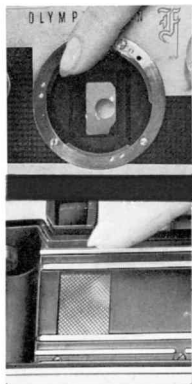

- When the lens is removed be careful not to put fingerprints on the mirror.
- The shutter screen is made from extremely thin metal and should not be touched. The shutter should be left in an open position (B) when the camera is not used for a long time.

- Do not leave the camera in dusty or damp places. Store it in a dry place with good circulation of air.
- Do not leave fingerprints on the lens. Wipe them off immediately with a clean piece of cotton cloth. If fingerprints are left on the lens for some time they are difficult to remove.

**NOTE:** It is not necessary to lubricate any part of camera.

## ATTACHING THE CARRYING STRAP AND CASE



Open the special link with the thumb and index finger and put it through the eye which protrudes from the side of the camera.

Open the hook at the end of the carrying strap and attach it to the link.

Put the camera into its leather case and tighten it by turning the knob which is located on the bottom of the case.

The front cover of the leather case can be removed by unsnapping it, or left on the bottom of the case where it pivots.





# ZUIKO AUTO ZOOM LENS F 3.5 f = 50~90 mm

## STANDARD LENS

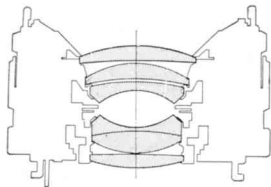

F 1.8 f = 38 mm

## THE EFFECT OF LENS REPLACEMENT

Various effects can be obtained by using different lenses.

Interchangeable lenses include zoom, wide angle and telephoto lenses. The most versatile of these is the zoom lens, because it allows the photographer to change the size of his subject freely.

Weights of Pen size lenses are one third of standard 35 mm lenses and size only one half, making them easy to carry.



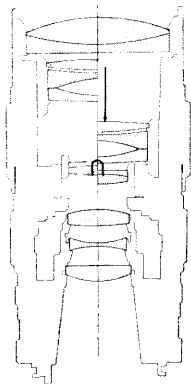

**ZUIKO AUTO ZOOM LENS F 3.5  $f=50\sim90$  mm**

The main features of zoom lenses are (1) a single lens can be used in place of many different lenses between 50 and 90 millimeters, and (2) effective composure may be made before the picture is taken to eliminate trimming. The special feature of the Zuiko Auto Zoom Lens is that, unlike other zoom lenses, it remains in focus throughout the complete zooming range. Its resolving power is extremely high.

# E ZUIKO AUTO-T LENS F 3.5 f=100mm

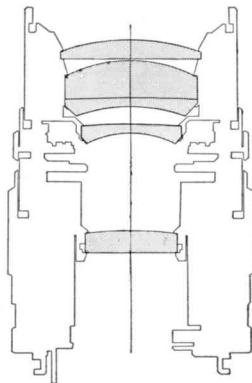

Like the zoom, this 100 mm Pen-size telephoto lens is small in size and light in weight.

Standard 35 mm cameras with telescopic lenses are unwieldy, but this smaller size makes it easy to work with—to increase the joy of telescopic photography.

# INTERCHANGEABLE LENSES AVAILABLE FOR THE PEN F

There are twenty interchangeable lenses for the Pen F, a representative number of which are listed at the right.

App. 35 mm Equivalent

F Zuiko	Auto- S	F 1.8 f=38 mm	f=55 mm
G Zuiko	Auto- S	F 1.4 f=40 mm	f=58 mm
E Zuiko	Auto-W	F 4.0 f=25 mm	f=35 mm
G Zuiko	Auto- T	F 1.5 f=60 mm	f=85 mm
E Zuiko	Auto- T	F 3.5 f=100 mm	f=143 mm
E Zuiko	Auto- T	F 4.0 f=150 mm	f=210 mm
Zuiko	Auto Zoom	F 3.5 f=50~90 mm	f=70~130 mm

## PEN F ACCESSORIES

Special CdS meter

Filters

UV • Y2 • 1A • R

Hoods for interchangeable lenses

Waist-level range finder

Magnifier

Close-up lens

Bellows

Camera holder

Flash unit bracket

Electronic flash

Microphoto adaptor

*Olympus Optical Co., was established in 1919 to manufacture top quality microscopes in Japan. Since that time every Olympus product has been manufactured with the same type of technical*

**OLYMPUS OPTICAL CO., LTD.**

*precision necessary for manufacturing microscopes.*

*Current products include microscopes, optical measuring equipment, medical instruments and others.*